



**CORPORATION OF
THE TOWNSHIP OF EAST GARAFRAXA**

Office Location: 065371 Dufferin County Road 3, Unit 2 East Garafraxa ON L9W 7J8
Telephone: 226-259-9400 or Toll Free: 877-868-5967 Fax: 1-226-212-9812
Email: info@eastgarafraxa.ca

ENTRANCE APPROVAL FORM

Owner/ Applicant:		Roll No.:	
Mailing Address:		Entrance Location (If different from mailing address):	
Phone No.:		Legal Description:	
Email:		Area:	Frontage:
Entrance Classification: <input type="checkbox"/> Residential <input type="checkbox"/> Farm <input type="checkbox"/> Field			
<input type="checkbox"/> New Entrance Installation <input type="checkbox"/> Relocation of Existing Entrance <input type="checkbox"/> Upgrade Existing Entrance			
Please attach a sketch or drawing showing the location and size of your property and the proposed location of the entrance. Proposed location must be clearly marked/staked at time of application.			
<ul style="list-style-type: none"> • I understand I need to obtain any required permits from the applicable Conservation Authority and obtain site alteration approval from the Municipality for any import and/or export of fill material pursuant to By-Law 14-2015, as amended from time to time, a copy of which is available on the Township website. • I have read and understand By-Law 24-2002, as amended (Office Consolidation included on reverse) 			
Signature of Owner/Applicant: _____		Date: _____	
Owner/Applicant to construct and maintain at their own risk and expense a private entrance to their premises/property which includes the portion within the municipal road allowance.			

(\$100.00 Fee & \$600.00 Deposit)

Office Use Only

Payment Amount:	\$700.00	Payment Method and Date:		Receipt Number:	
Severance File No.:		Zoning:		Date:	
Entrance Proposed in Conservation Protected Area?: Yes <input type="checkbox"/> No <input type="checkbox"/>				Conservation Permit No.:	
CULVERT SPECIFICATIONS					Permit Number: _____
Location Approved by Director of Public Works:					
Culvert Diameter: _____		Length: _____			
Signature of Director of Public Works: _____				Date: _____	
Subject to Subdivision Agreement: Yes <input type="checkbox"/> N/A <input type="checkbox"/>					
Comments: Rocks are not to be placed around culvert or on roadside beside driveway; Ends should be sloped 3:1 feet (3 feet horizontal for every 1 foot vertical); Ends should be top soiled and seeded or sodded; Culvert should be free from any debris; and Driveway entrance should be level with roadway-minimum 6 metres.					
Additional Comments: _____ _____					

Final Inspection by Director of Public Works:

Signature of Director of Public Works: _____ Date: _____

Refund Date:		Cheque Number:	
---------------------	--	-----------------------	--

This is a consolidation of the Township's By-Laws for regulating, construction and installation of entrances, being By-Law 24-2002 as amended by By-Law 42-2018, which has been prepared for reference and information purposes only. The following consolidation is a reproduction made available for information only. It is not an official version of the By-Laws. Official versions of all By-Laws can be obtained from the Township by calling (519) 941-1007. If there are any discrepancies between this consolidation and By-Laws 24-2002 and 42-2018, the By-Laws shall prevail.

**THE CORPORATION OF THE TOWNSHIP OF EAST GARAFRAXA
BY-LAW NUMBER 24-2002**

(Office Consolidation Including Amending By-Law 42-2018)

**BEING A BY-LAW FOR THE REGULATING, CONSTRUCTION
AND INSTALLATION OF ENTRANCES**

WHEREAS the Municipal Act, R.S.O. 1990, Chapter M.45, Subsection 207 (17), authorizes Councils of Municipalities to pass by-laws for permitting and regulating the size and mode of construction of any culverts and bridges that cross any drain or watercourse situated on a highway under the jurisdiction of the Municipality;

AND WHEREAS it is deemed desirable by the Council of the Corporation of the Township of East Garafraxa to ensure proper installation of entrances under the jurisdiction of the Municipality;

NOW THEREFORE the Council of the Corporation of the Township of East Garafraxa enacts as follows:

1. No person shall construct or install a roadside culvert by private contract or by his own person on any land owned or under the jurisdiction of the Township of East Garafraxa without first obtaining permission from the Township.
2. Entrances shall be installed to the specifications of the Township of East Garafraxa.
3. In the case where the building or land to be served by the culvert requires a building permit, no building permit shall be issued until a deposit has been received by the Treasurer for the Township of East Garafraxa.
4. The deposit shall be \$600.00, and a non- refundable fee of \$100.00 to be collected before the building permit is issued, or in the case where a building permit is not required, then prior to installation.
5. Upon satisfactory final inspection of the entrance, the \$600.00 deposit shall be refunded.
6. If the entrance is found to be unsatisfactory, the deposit shall be held until corrected. In the event that the Township of East Garafraxa is required to repair the entrance, costs shall be deducted from the deposit and any remaining funds shall be returned. If the costs incurred by the Township exceed the deposit received, the balance shall be deemed to be due and payable to the Township.
7. It shall be lawful for an owner and occupant to construct and maintain at their own risk and expense a private entrance to their premises which includes the portion within the municipal road allowance and shall conform to the requirements set out by the appropriate authority.
8. That this By-Law shall take effect and come into force on the date of passing.
9. That By-Law 4-2002 be hereby repealed.

BY-LAW READ A FIRST AND SECOND TIME THIS 21ST DAY OF MAY, 2002.

BY-LAW READ A THIRD TIME AND PASSED THIS 21ST DAY OF MAY, 2002.

Susan M. Stone, Clerk

Earl Lennox, Head of Council

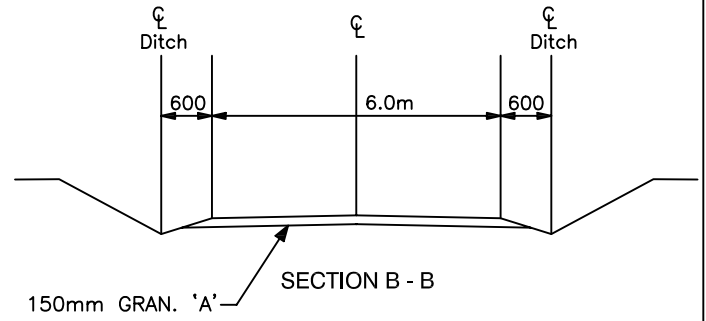
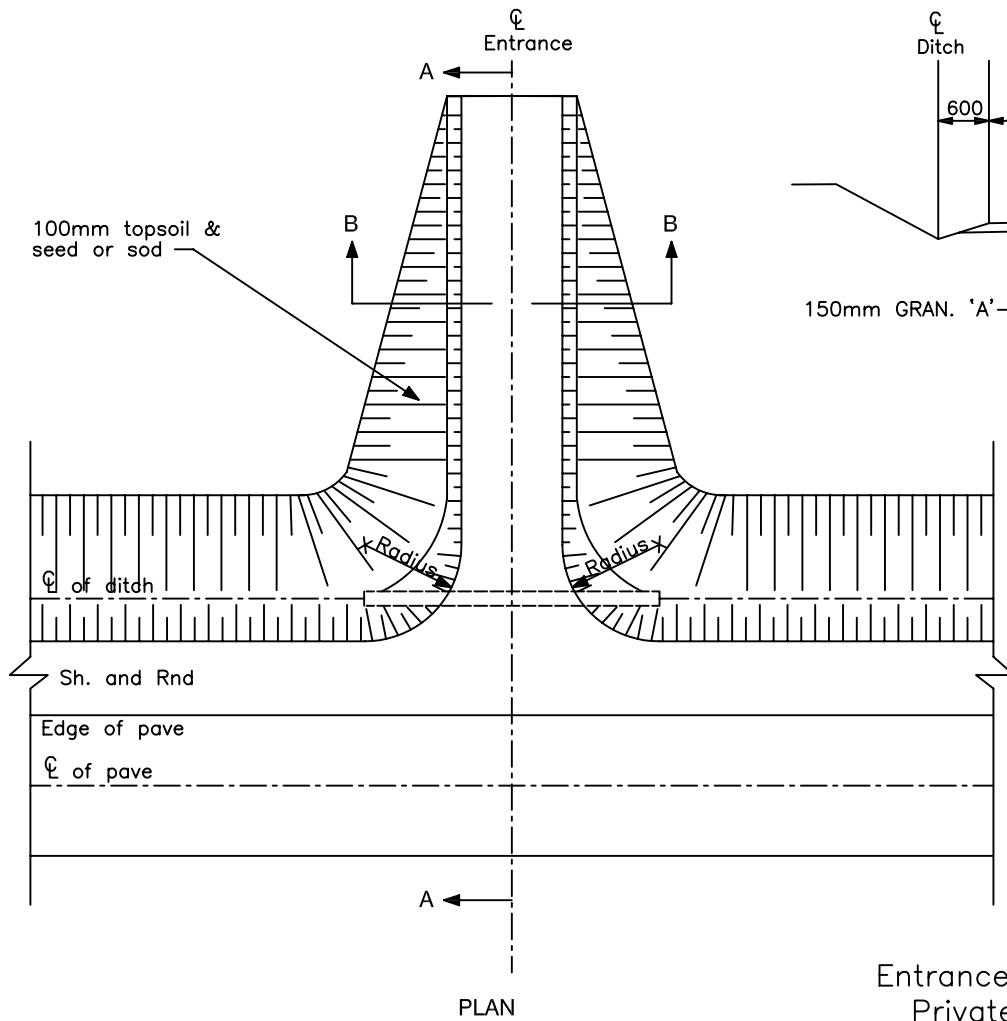

Entrance radii
 Private or field - 5.0m
 Farm - 10.0m

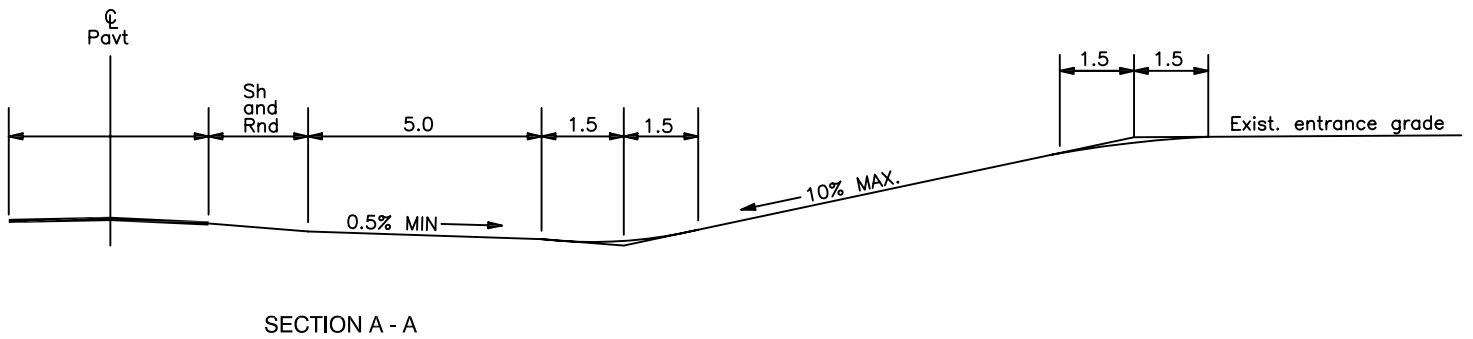

Culvert
 Min. Dia. 450mm
 Min. cover 300mm
 Min. length 10m

EARTH CUT

NOTE: All dimensions are in meters or millimeters unless otherwise specified.

Township of East Garafraxa

ENTRANCE
 RESIDENTIAL, FARM OR FIELD

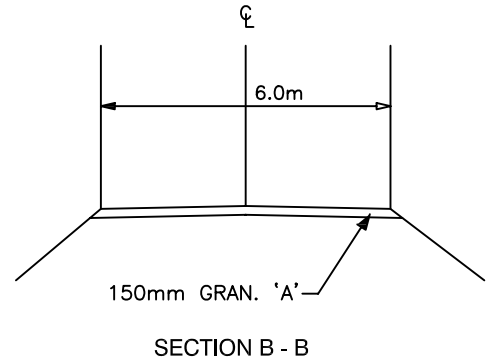
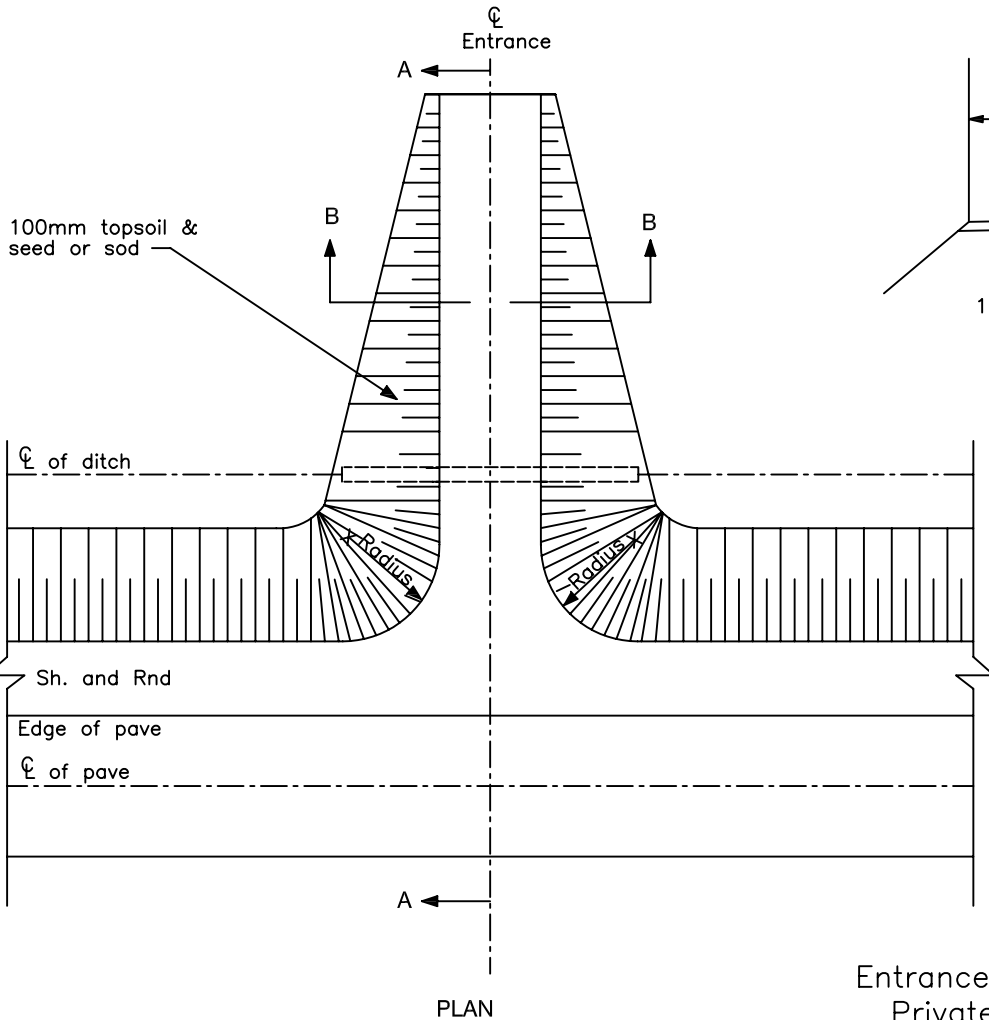

Entrance radii
 Private or field - 5.0m
 Farm - 10.0m

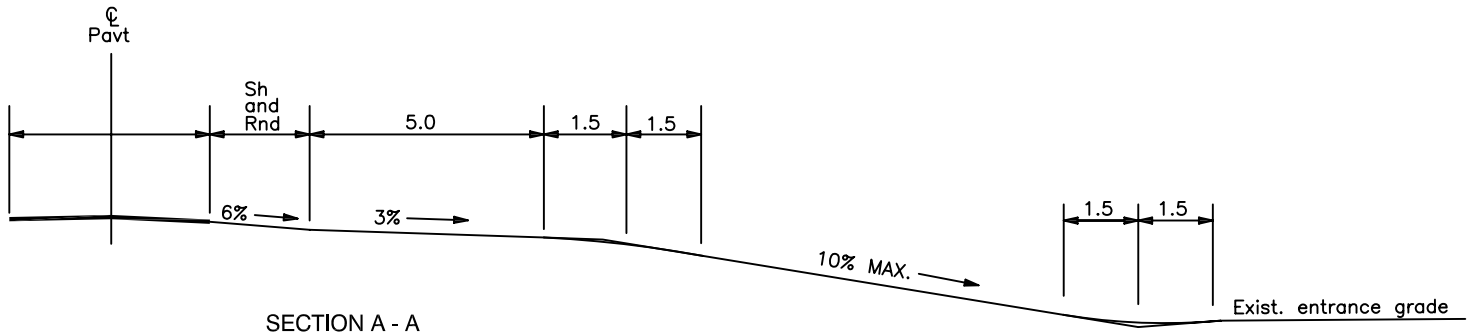

Culvert
 Min. Dia. 450mm
 Min. cover 300mm
 Min. length 10m

EARTH FILL

NOTE: All dimensions are in meters or millimeters unless otherwise specified.

Township of East Garafraxa

ENTRANCE
 RESIDENTIAL, FARM OR FIELD